



NEWSLETTER

Official Organ UNICYCLING SOCIETY OF AMERICA Inc. ©1974 All Rts Res.
Yearly Membership \$3 Includes Newsletter (4) ID Card - See blank Pg.11

OFFICERS

Pres. B. Crandall
V. Pres. Paul Fox
Sec. T. Gordon Kruse

CHARTER MEMBERS

Bernard Crandall
Paul & Nancy Fox
Peter Hangach
Patricia Herron
Bill Jenack
Gordon Kruse
Steve McPeak
Fr. Jas. J. Moran
Dr. Miles S. Rogers
Charlotte F. Rogers
Andy Rubel
Dr. Claude Shannon
Dr. Jack Wiley

NEWSLETTER EDITOR

Bill Jenack
67 Lion Lane
Westbury, NY 11590

FELLOW UNICYCLISTS: In response to requests from cyclists for some type periodical through which they might receive and exchange news and ideas on the sport this quarterly newsletter is being launched. It is planned to cover areas of general interest such as: Construction & Riding Hints, Historical Notes, Current Events, Articles on Cyclists of Note, and a Question and Answer Department. - A word now about your Editor:

Bill Jenack has been unicycling since 1933. Worked way through college doing magic, gymnastics and trick cycle riding. Has been teaching others to ride for past 40 years and has perfected a teaching system whereby beginners ride almost at once. Author of a number of magazine articles and instruction sheets on unicycling and founder of 'Jenack Cyclists' a group of over 500, many of whom perform at civic affairs on Long Island. Resides in Westbury with wife Mary, and sons Bill Jr. and John, all of whom also ride unis. A former teacher, pilot, machinist, flt. test tech. and aerospace telemetry systems operator, he is now with Analog Computer and Simulation Dept. of Fairchild Republic Co. in Farmingdale, N.Y. Has a collection of old & novel vaudeville and circus cycles used by famous performers and for years has corresponded with other cyclists everywhere. Feels unicycling has finally come of age and is one of the most wholesome and satisfying activities for teenagers and adults alike. Hopes this newsletter will help give it the boost it deserves.

PROFILES: The late Hon. Hudge Edison Hedges whose inspiration & encouragement played a large part in founding of this newsletter (Reprinted through courtesy Atlantic City Reporter)

CURRENT UNICYCLING NEWS:

Pg 3

National Meet in Pontiac June 30 - July 1, 1973
Plans for holding 1974 Meet in Marion, Ohio
Steve McPeak's World's Highest Uni Finds Permanent
Home in Amer. Bicycle Hall of Fame, Richmondtown, S.I.
Dr. Wiley's New Comprehensive Book On Unicycling

CONSTRUCTION AND RIDING HINTS:

Learning To Ride A Unicycle In A Hurry Pg 4
Neat Maneuvers - Couple Under-Arm Turn Pg 5
Details of Walter Nilsson's Mini-Uni Pg 6

THE QUESTION BOX:

Pg 7

Giraffe Unicycles - Where They Come From
The World's Longest Recorded Unicycle Rides
Walter Nilsson, Steve McPeak, Wally Watts
Proper Saddle Height for Unicycles

MISCELLANEOUS: Club and Individual News

Meet Your Officers and Charter Members Pg 8
"Wonderwheels" - "Jenack Cyclists" Pg 9
General News Items From All Over Pg 10
End Of The Trail - Passing of Great Unicyclists Pg 11
Eddie Hedges, Rudy Yung, Sebastian Neuhausen

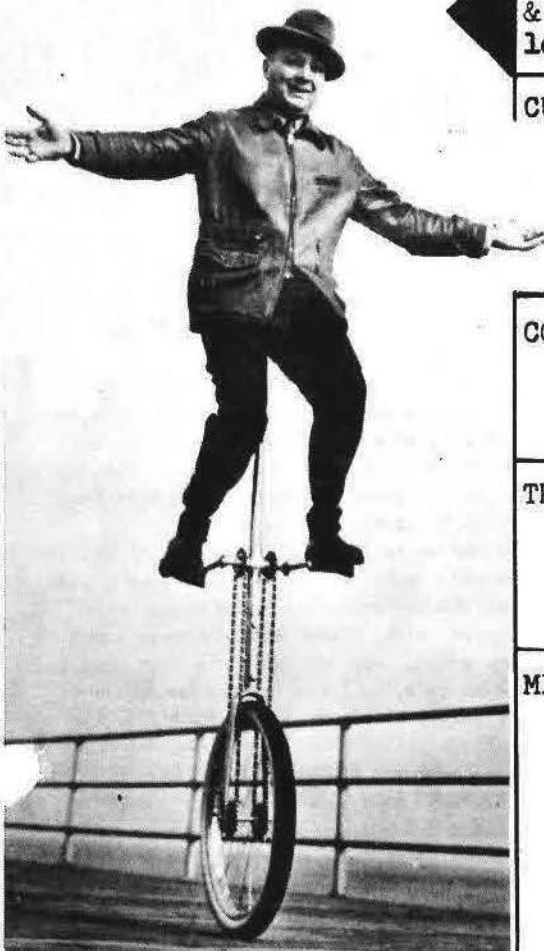

GREATER ATLANTIC CITY - VENTNOR - MARGATE - LONGPORT ATLANTIC CITY

Page 2

REPORTER



AR

FRIDAY, OCTOBER 11, 1968

THE BOARDWALK IS MY BEAT BY CHARLES E. SEEL



"A Well Balanced Judge"



"Look Ma!...No Hands---and---only one wheel!!!!... When we first looked, we couldn't believe our bikes!!!... Nor...could we, this "Master of extraordinary eccentricities!!"... U-S-A Inc. NEWSLETTER 1-74

You don't have to look too closely to recognize that its our popular local Jurist, the Honorable Judge Edison Hedges--and the thousands who know and respect him will vouch that this is not trick photography...Actually, the Judge is a pro-performist on this unique contraption called the unicycle--which by the way is one of the most difficult devices to learn.

The Judge, whose court is held in reverential regard and in the highest esteem, and his ruling principle of conduct being kindness and courtesy, is a man who, despite his brilliant legal background, is of the adventurous mind, always seeking the infinite. He abides by the rule of reason, and his many accomplishments in the extraordinary justifies his faith in good sense.

To have truer and greater capacity to appreciate his many capabilities, would be to listen to his genius and his proficiency in playing the cello--his recordings of the many classics holds the listener spellbound...and his numerous other versatile accomplishments along with his speedboat racing championships are today legend and will no doubt be listed in the annals of our resort's sports-history.

Today, October 11th is Judge Edison Hedges birthday, and from his remarkable youthful appearance it merely marks the date of his birth, for if we liken him to the replies of the famous Jack Benny, he too can say that he is only 39, and is a contagion example of being "young at heart."

The most thought-commanding question would be to ask the Judge how or why he selected to ride this un-conformable one-wheel bike, the unicycle.

His answer to this was, and we quote;

"Some 20 years ago, I saw a chap name of Willie Richie" perform on Steel Pier in the vaudeville show as a tramp cyclist. I was fascinated with Richie's act--his ability to ride bikes of all description, from the tiny roller skate size, to the one I mostly prize, the unicycle."

The Judge warmly continued with; "I decided right then, that to learn, and also be able to perform like Richie would be a happy experiment. Thus Willie Richie and I became friends and he promised to teach me his act.

"Unfortunately, however, his sudden passing was an instantaneous but momentary cessation of my ambition.

Shortly thereafter I contacted his widow and was thus able to purchase all of his bicycle equipment--which by the way was a huge truckload that was hauled here from New York and which filled my entire garage.

"With awed devotion to the task, I practiced every day, for many months until I had Willie Richie's act "down pat" from the roller-skate bike to the unicycle!"

Hedges concluded with, "And the greatest satisfaction for all my effort, was not only the fact that I could now ride the unicycle, but I was booked for 18 shows at Steel Pier--the money of which, I contributed to the, then, war fund."

Thus in joining with his thousand of his friends and admirers, the REPORTER STAFF says; "HAPPY BIRTHDAY" to Judge Edison Hedges--with many, many, many more to come!...And may his story and mighty spirit of adventure, and his accomplishments of what some would think impossible, be inspiration to our youth of today.

NATIONAL UNICYCLE MEET - PONTIAC, MICHIGAN, June 30 - July 1, 1973

In the summer of 1973 a National Unicycle Meet was held in Pontiac, Michigan. It was co-sponsored by Bernie Crandall's Pontiac Unicyclists and the Pontiac Optimist Club. Unicyclists were attracted from near and far and the Meet lasted two days. On Saturday June 30, 1973 some two dozen individual competitive races were held at the Waterford Township High School track and awards were given for the first three places in each of the races. In addition 4-member Relay Races of 440 yds were held for boys and for girls. A special trophy for the One Mile Race was presented by the Pontiac Optimist Club and was happily won by a Pontiac unicyclist Floyd Crandall who rode the mile in 4Min 46.1 Sec. Group participation events took place on Sunday July 1, 1973 in the huge Pontiac Mall parking lot and awards were presented for group drills and formations and for trick riding. In addition drawings were held for other donated prizes consisting of two regular and one giraffe unicycle and fifteen other smaller prizes. Appropriately enough the drawings were all made by the world's outstanding totally blind unicyclist John Lizza of Carle Place, New York. Mr. Lizza and his partner John Jenack of Long Island also took a prize in one of the trick riding events.

A special 10 page brochure on the meet with list of all events and winners has been compiled and will be mailed to initial subscriber members of the Unicycling Society of America, Inc. If additional single copies are desired they may be obtained for 50¢ from secretary Gordon Kruse whose address appears on page 11.

Another National Unicycle Meet is planned for 1974. It will be held on August 17-18 in Marion, Ohio. Look for additional information in next issue of newsletter. Mr. Paul Fox of the Paul Fox Unicycle Club, Inc., 983 E. Center Street, Marion, Ohio 43302 is in charge of the 1974 National Meet and will welcome any comments or suggestions you may have relative to the meet.

WORLD'S HIGHEST UNICYCLE FINDS PERMANENT HOME

The 31'2" Unicycle upon which Steve McPeak, on Feb 2, 1969, set a world's record for the highest unicycle ever ridden is now on display in its new permanent home The American Bicycle Hall of Fame Museum located in the historical Richmondtown Restoration, Richmondtown, Staten Island, New York. It was donated by Steve who shipped it to Bill Jenack in Westbury, L.I.. Bill restored and delivered it to the Museum on July 7, 1973. Motorists on the Long Island Expressway that day were dumbfounded to see a 31' unicycle being transported in two sections atop a Volkswagen Squareback. Spectators were equally bug-eyed when they witnessed Loring McMillen, Dr. Geist, and Bill Jenack raising the monstrous unicycle horizontally in two pieces and inserting it in a second story window at the Museum. (It was too long to go up either of the staircases but a couple ropes over a convenient tree limb did the trick)

AT LAST, A COMPLETE BOOK ON UNICYCLING

Hurray - the one thing we've all been looking for for years has finally arrived. It is a complete book on all phases of unicycling. Written by Dr. Jack Wiley, a unicyclist himself and gymnast of note as well as a charter member of our organization. The book is profusely illustrated and contains a wealth of information on the history of unicycling - famous performers - methods of teaching - construction articles - ideas for unicyclists - and news and pictures of unicycling groups all over the United States. As stated on the jacket it is the first complete reference to Fun on One Wheel. THE UNICYCLE BOOK is obtainable through any bookstore and is published by Stackpole Books, Cameron and Kelker Streets, Harrisburg, Penna. 17105. It sells for \$7.95 and in your editor's opinion is destined to become the handbook of the sport.

WALLY WATTS COMPLETES 3 MONTH, 4550 MILE UNICYCLE RIDE ACROSS CANADA

(See Questions and Answers Page 7)

Use 20" Uni with 5½" crank
Set saddle height as on Pg 7

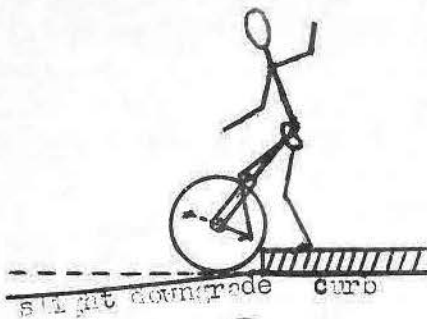

①

Climb on at curb like this
Slight downgrade is of help
Helpers hold hands only

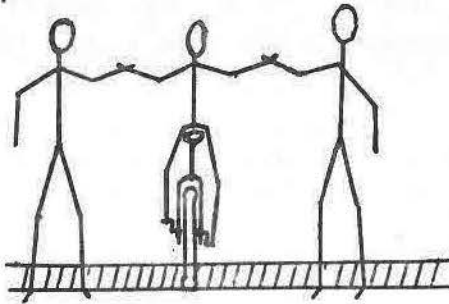

②

Helpers directly at sides
Rider sits up straight
Looks forward - not down

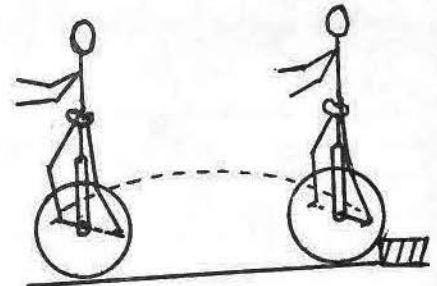

③

Using helpers at sides
Rider pedals ½ revolution
of wheel at a time

HINTS:

Strive to move the saddle smoothly forward with you each half revolution of the wheel. If you fail and find you are falling simply straighten both legs and stand up on both pedals squeezing saddle between legs to keep it in place and let helpers restore your balance for you after which you can sit again and make another try.

Adjust your posture and balance so you are sitting up straight and not leaning or putting pressure on your helpers hands in any direction.

It is interesting to note that to ride forward one must always push slightly on the aft pedal in order to establish a forward lean. The forward lean then compels rider to pedal forward in order to maintain balance. Do not confuse lean with bending at the waist - do not bend at waist, (even though instinct tells you to do so) instead see how quickly you can acquire the feeling of being balanced directly over the axle. After riding forward "steady by jerks" several half revolutions, try a full revolution or two at a time before pausing to regain complete balance.

Once you have mastered sitting up straight you will find one helper is all you need. Next try letting go of helper's hand momentarily while riding and clapping your own hands 1,2,3 times etc. You will soon find you do not need helper at all. Whenever you dismount try to do so to the rear and catch the saddle - they wear out if dropped.

The SECRET of learning to ride quickly is to sit up straight and use as little pressure as possible on helpers hands unless you are actually starting to fall. When that occurs simply spring to a standup position on pedals, with both legs straight and hold saddle by squeezing between legs. Helpers will be able to restore your balance instantly if you freeze in this position. You can then sit back down on saddle in proper posture and balance and make another attempt at a half revolution of wheel. If you make a point, during learning period, to never rock back and forth when holding a helper's hand you will decrease learning time significantly and quickly become a very smooth rider. Holding helper's hands only, as stressed in beginning, means the helpers are able to supply your side to side balance and prevent you from twisting yet will not inhibit your feel for the forward-back balance which you will consequently learn in a matter of a very few minutes.

As soon as you find you can get along with just one helper practice climbing on each time without the use of a curb. To do this place one foot on the pedal at bottom, step up onto other pedal and draw it back one third to one half revolution, straighten up and 'freeze' in this position and allow your helper to put you on balance. If you do this each time you climb on you will have it mastered by time you first solo and your future progress will be extremely fast as you won't waste time trying to mount.

If you are aiming to become an outstanding rider do not put off learning to ride backwards but tackle it immediately - more about that in the next issue.

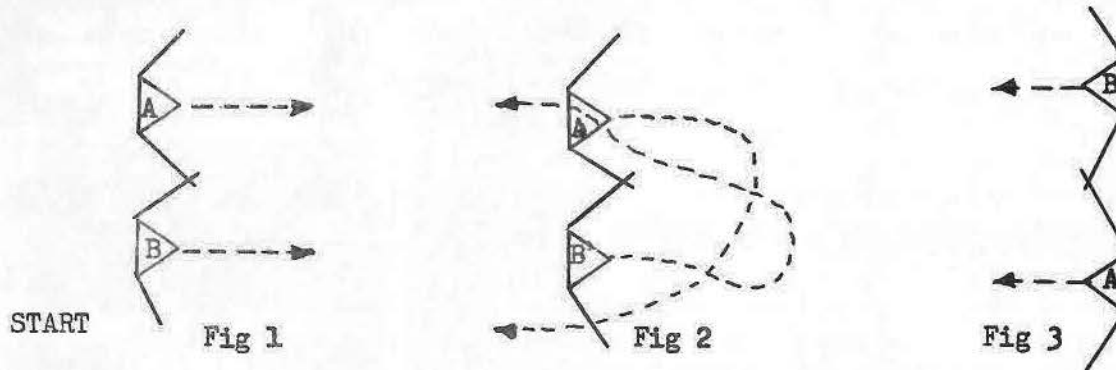

Two or more riders performing together on unicycles can present a smoother and more confined riding act than one alone because they can assist each other in making graceful turns and spins.

A neat "Quick Reversal of Direction" for two riders is depicted in the sketches above. Properly executed this is a beautiful turn to behold and adds a real professional touch to an act.

It starts with the two cyclists riding side by side close together and holding inside hands (Fig 1).

When ready to make the turn, if rider "A" will push rider "B" away from him slightly and if rider "B" will look to his right and move that direction a foot or two (as far as arms will allow) before making his left hand turn to ride under the upraised arm of rider "A", they will find they have the necessary clearance to complete the figure without running into each other.

While rider "B" is turning and riding under the other's upraised arm (Fig 2), rider "A" should cut across to the right, turning to wind up as in Fig. 3. The two riders are now headed in the opposite direction and once more are riding side by side still holding hands and slightly apart from each other.

A little practice and close adherence to the above sketches will result in the riders as well as the spectators getting a thrill from this neat turn.

As "B" cuts back under the upraised arms, "A" get the feeling of a bull fighter letting a raging bull charge by his cape. Once the proper lean is mastered for this part the whole turn becomes one smooth and graceful maneuver.

If the above is used in a parade and the parade regulations require constant forward motion simply do two of these in quick succession and continue in the line of direction.

Upcoming issues of newsletter will have more of these performance tested maneuvers and ways to combine them to make up a complete act.

If you have a pet maneuver you would like to share with others send it in.

One of the favorite types of novel cycles with unicyclists everywhere seems to be the mini-wheel unicycle. Drawings shown here are of an 'oldie' made and ridden by Walter Nilsson, one of the all time greats. Nilsson was the unicyclist who won a \$10,000 "Believe-It-Or-Not" Ripley prize for the most incredible feat of the year 1933. He rode his 8 foot unicycle from New York to San Francisco in 117 days. (3386 Miles)

It is interesting to note how he solved the drive problem in this unicycle. He simply took an old brass track-bike hub with fixed sprocket, sawed it in half, telescoped the two halves and riveted them back together to make a narrower hub upon which he slipped a hard rubber tire resembling a plain donut. To mount the tire he ground off most of the flange on the side opposite the sprocket. Then after winding a few layers of friction tape on the hub he slid the tire on and then a collar which was held in place by a few set-screws.

This unicycle is still in operating condition and often used by Jenack Cyclists of Westbury, N.Y. in their performances. It was obtained from Eddie Hedges of Atlantic City, N.J. who purchased it from Nilsson for fifty dollars in the 30's.

These drawings may give readers ideas and dimensions for constructing their own. The cycle is a challenge to ride and makes a good transition cycle to the higher giraffes.

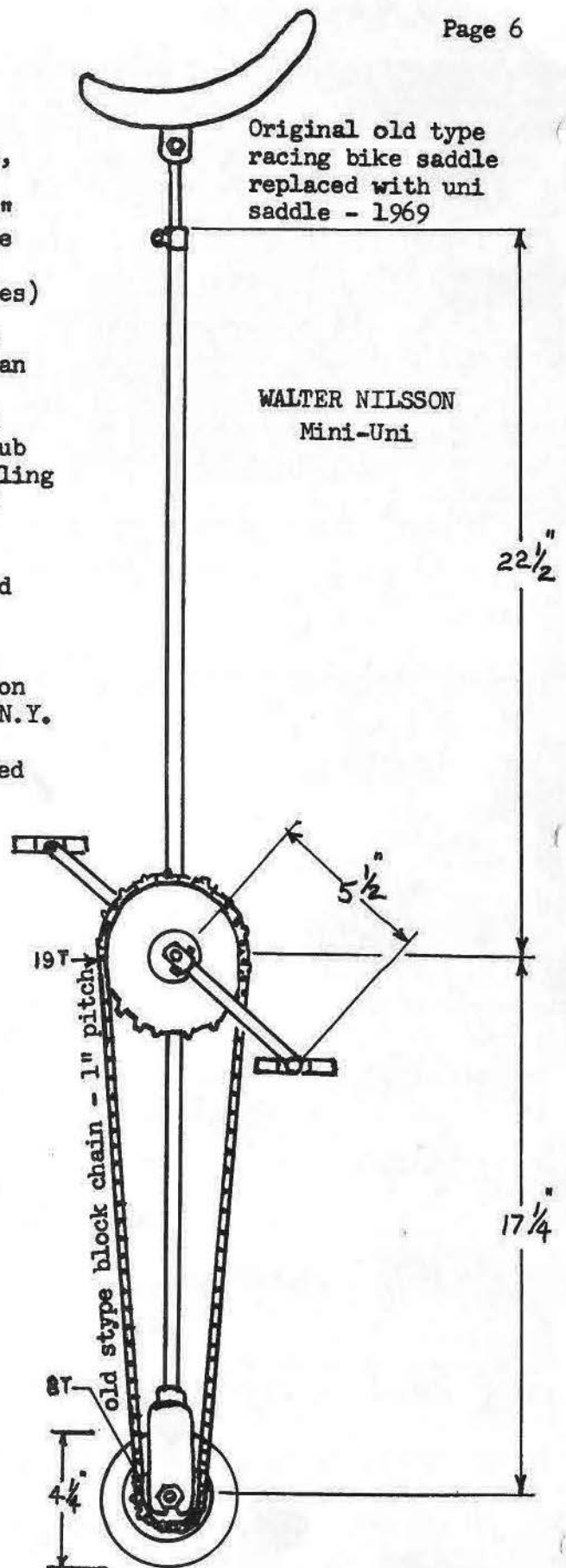
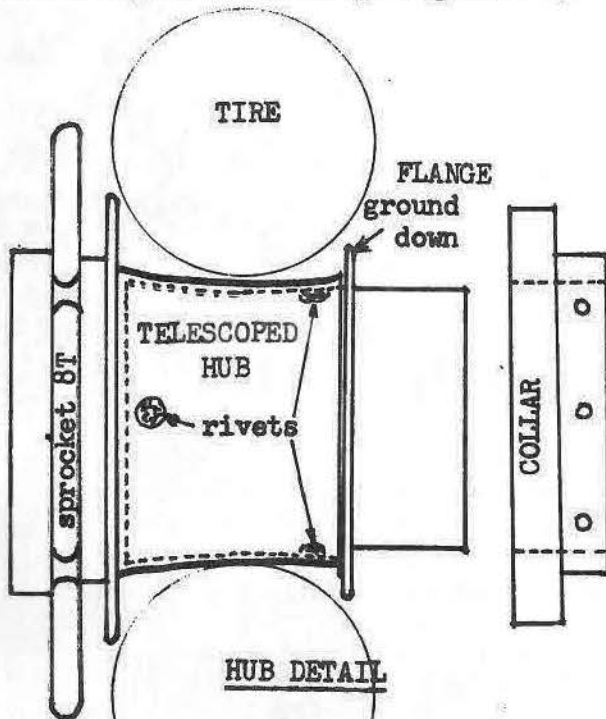

- Q. What is the story on giraffe unicycles - how or where does one get such a cycle?
- A. At the present time the only commercially built giraffe uni is the 6' Oxford P-21. Made in Japan, it was designed by Sykes of Chicago, a famous old time vaudeville and circus cycle builder, who knew his stuff. Should your local cycle dealer be unable to supply you, drop your editor a line and he may be able to get you one.

If you weigh over 180 lbs you may wish to invest in a custom built model.

Three builders from which such are obtainable are:

Mr. Emmett Carpenter	Mr. Bernard Crandall	Mr. Dave Lepard
"Hamiltons" The Bicycle Store	Pontiac Unicyclists	City Cyclery
1622 South Parkwood Lane	124 South Josephine	670 Mentor Avenue
Wichita, Kansas 67218	Pontiac, Mich. 48053	Painesville, Ohio 44077

All three of the above have built many chain driven high unicycles which eliminates the chance of you winding up with a cycle that is unrideable.

A construction article on building your own giraffe uni from standard bicycle parts is planned for a future issue of this newsletter - keep your eye out for it.

Some Timely Hints On Giraffes:

Do not attempt to ride a giraffe until you can idle in place and ride backwards easily on your regular 20" or 24" unicycle. Six to eight feet is about the highest giraffe you can scramble onto easily without additional props. Spectators find a six to eight foot unicycle quite impressive and such a uni is fairly safe even if you do occasionally lose your balance and have to dismount. Higher model in addition to being less safe and requiring props for mounting has a tendency to be self destructive if you fail to catch it upon dismounting. Even a six footer can be damaged if you let it fall when you dismount. Making it of heavier stock does not solve the problem as the additional weight makes it more likely to bend the crank arms and frame and destroy the pedals and saddle when it is dropped. Unless you have a group of experienced unicyclists and use various size unis to create a comparative effect, it is questionable if the use of higher models warrant the additional risk and the extra props involved.

- Q. What is the longest recorded unicycle ride and who was the rider?
- A. In terms of distance, Wally Watts of Edmonton, Alberta, Canada just recently completed an incredible 4550 mile ride across Canada from the Pacific to the Atlantic Ocean in three months and a day (May 26 - Aug 27, 1973). A future issue of this newsletter will carry the complete story.
- In terms of continuous riding, one of our own members, Steve McPeak rode a unicycle for 23½ hours and covered 186 miles which is the fastest and longest continuous ride ever recorded. Steve also holds the record for riding the highest unicycle in the world (31'2") - see note Pg 3 - Current Unicycling News. In addition Steve is noted for his over 2000 mile ride on a 13 foot uni, from Chicago to Las Vegas in the Fall of 1968. A few months later he was on his way again and continued riding his 13 footer all the way to Los Angeles, California.

- Q. What is the proper height for a unicycle saddle?
- A. Same as for Bike - When sitting on cycle with pedal at bottom, and heel on pedal, leg should be straight. Then when you ride, with ball of foot on pedal, leg will be just slightly bent when pedal is at bottom. One of most common beginner's faults is riding with too low saddle. Not only is it very tiring to ride with legs bent all the time but it results in poor riding posture which later on will make spinning difficult. A crankarm longer than necessary is also very tiring as it results in wide leg excursions when pedaling. For 24" wheels, arms longer than 6" should be avoided unless needed for special steep inclines. 5" to 5½" arms are sufficient for 20" wheels.

IF YOU HAVE A QUESTION ON UNICYCLING YOU THINK WOULD BE OF INTEREST TO OTHERS - SEND IT IN AND WE'LL DO OUR BEST TO DIG UP THE ANSWER.

Bill Jenack

BERNARD E. CRANDALL - Bernie, our first president and the founder of Pontiac Unicyclists is an imaginative and tireless leader and the performances of his group reflect the hours he has spent organizing them and even building the giraffe unis they use in their drills. The unique riding props he has designed and built - teeter boards, ramps, steps, etc. are evidence of his genius and intense dedication to the boys and girls and unicycling.

PAUL AND NANCY FOX - Leaders of the very active Paul Fox Unicycle Club, Inc. of Marion, Ohio. Their club is noted for their group riding and their outstanding colorful costumes; the handwork of Nancy Fox. Vice President of our organization, Paul has a lot of great ideas and is eagerly looking forward to next year's National Meet which his group plans to sponsor in Marion, Ohio on Aug. 17-18, 1974

GORDON KRUSE - As secretary Treasurer Gordon is shouldering much of the load of getting our organization under way. His amiable wife Pauline and two sons John and Jim are very active in the Pontiac Unicyclists Club. The geographical nearness of his home in Farmington, Mich. and that of Bernie Crandalls in Pontiac is a real asset to him in the efficient carrying out of the duties of his office.

PETER HANGACH - Pete, a Recreation Director for town of Chardon, Ohio has an enviable reputation for outstanding work with the youth of the community and one of his interests happens to be unicycling. As Unicycling Director of Father Moran's group in Newbury, Ohio it was Pete who originally worked up the St. Helen's Crazy Wheels to fulfill Father Moran's dream of an outstanding unicycle group. Pete also founded the St. Benedict's Happy Wheels group in Cleveland and they have also received widespread publicity for their outstanding unicycling performances.

PATRICIA HERRON - At present a college student at St. John's College, Patricia has for several years been a mainstay of the Jenack Cyclists in Westbury, N.Y. An outstanding performer and an ambitious organizer Pat has been a real help to the movement. Her three younger sisters are also unicyclists of note and perform regularly with Jenack Cyclists.

BILL JENACK - See Page 1 and "Jenack Cyclists" Pg 9

STEVE McPEAK - Steve is probably the world's most outstanding unicyclist at present time and has received a great deal of publicity in past six or seven years. Some of his accomplishments are: Riding his 13 ft. uni from Chicago to Las Vegas and then on to Los Angeles in 1968-9; Riding 23½ hrs straight on a 26" unicycle and covering 186 miles. Riding 20 ft uni on tightwire with partner on shoulders, riding a tandem (one above the other) unicycle (giraffe type) on a tightwire, walking a tightwire on ten ft. stilts, setting world record for height by riding a 31'2" unicycle. The past two years Steve has been working his high wire uni and stilt act with circuses in Mexico and Western U.S.A.

FATHER JAS. J. MORAN: Father Moran is the founder of St. Helen's "Crazy Wheels" of Newbury, Ohio. The group consists of the student body of St. Helen's Parochial School in Newbury, Ohio. The entire student body rides and they have probably had more publicity than any other group in the country. They have been sponsored by Goodyear and have been on many TV shows and in many parades and festivals all over the country.

DR. MILES S. ROGERS and CHARLOTTE FOX ROGERS - See Special "WONDERWHEELS" write-up Pg 9

ANDY RUBEL - Andy, who hails from Miami Beach, is a gymnast and a Computer Science major at Massachusetts Institute of Technology. As a college freshman in 1970 he started the M.I.T. Unicycle Club. By 1973 the club had accumulated some 60-70 riders and is an active organization on campus providing training unicycles for beginners and conducting teaching sessions every Sunday PM in front of the M.I.T. Student Center.

(Continued on next page)

DR. CLAUDE SHANNON - Dr. Shannon, whose wife Betty presented him with his first unicycle over 20 years ago, now has over two dozen novel cycles in his collection and is about an avid a unicyclist as you could find anywhere. In his own words he is: "A mild mannered M.I.T. Professor by day, but a wild eyed unicycle inventor and rider by night". His mild manner belies the fact that he is the Dr. Shannon of "Information Theory" fame and who in 1972 won a coveted Harvey award for outstanding achievement in the field of science and technology. His two sons Bob and Andy and his daughter Peg are also very clever unicyclists and thrilled their dad with an outstanding performance at the World's First Invitational Unicycle Competition sponsored by the Stelber Company and held in New York City's Central Park Oct. 2, 1971. Andy and Peg, who competed in the meet took 1st and 2nd place in the Trick Riding Event. Peg also amazed spectators with her performance on an "Ultimate Wheel" (wheel with pedals but no fork or saddle).

After noting the levels of achievement his wife Betty had to go through to reach the level of Master Weaver in her hobby, Claude dashed off a very humorous list of requirements for unicyclists - ranging from Apprentice, Journeyman, and Master, to "Lord of the Wheel". With his permission we will include it in our next issue and let everyone have a chuckle.

DR JACK WILEY - Dr. Wiley has recently left his position as a research physiologist at Univ. of Calif. to take up free lance writing full time. Author of many papers involving scientific treatment of mechanics of gymnastics and human factors, he has also written construction articles on boats, bicycles, unicycles, and skill toys. In the past, information on unicycling has been very hard to come by - now suddenly The Unicycle Book, containing a wealth of information on all phases of the sport, has made the scene. See Page 3 for additional information on Dr. Wiley's book.

* * * * *

In addition to each issue's cover photo and feature write-up of a unicycling group or personality plans are to include two or more additional short articles on other unicyclists to enable readers to become acquainted with more groups in a shorter time. Herewith are two; one from West coast and one from East

WONDERWHEELS Wonderwheels is a performing unicycle drill team established in 1964 by Charlotte Fox Rogers and Dr. Miles S. Rogers in a community which later became the city of Carson, Ca.. Originally consisting of Dr. and Mrs. Rogers, their four children and up to 20 neighborhood children, it became strictly a family team when the Rogers moved to their new home in Cerritos in 1970. To date Wonderwheels has made 147 costumed public appearances. The Rogers have ridden their unicycles in some 35 states, 4 Canadian Provinces, (including an appearance at Expo 67), and 2 Mexican states. A feature story planned for a future issue will contain a complete account of Wonderwheels history, achievements, and honors received for outstanding skill and community service.

JENACK CYCLISTS An informal group of several hundred unicyclists in the Westbury-Levittown area of Long Island, which for many years have put on unicycling demonstrations at county parks, participated in parades, and entertained at civic affairs and benefits. Their unicycling is one of the most popular of many activities conducted by Bill and Mary Jenack over the past 22 years as a service to the community. The group's other activities have included Swimming and Diving, Tumbling and Gymnastics, High Bar work, Tightwire walking, Square and Folk Dancing, Mountain Hiking, and Skydiving. A computer technician with Fairchild Republic Company in Farmingdale, N.Y. Bill was once a high school electronics teacher who worked his way through college as magician, acrobat, and trick cyclist. As founder and for past five years, leader of the Unicyclists Association of America he has corresponded with hundreds of unicyclists the world over and has collected much material on the sport.

The Dec. 1973 issue of BICYCLE SPOKESMAN magazine carries 4 pages of information and color pics on Unicycling. Two happy college girls riding their giraffes in full page picture on Pg 22 are Jody Taylor and Lisa Morgan, two Jenack Cyclists of Potsdam, N.Y.

Recent letter and well wishes from Bob Starbuck was gratefully received. Bob was the Riding Instructor at Salt Lake City Kiwanis Felt Boy's Club which received considerable publicity about the year 1967 for their club's novel unicycling activity. His employment is taking him to Sacramento area where we hope he will start up another group.

Texas A&M Univ. Unicycling Club contacted Johnny Hart the artist whose syndicated comic strip B.C. often depicts a unicyclist - result they now have a real neat club emblem he designed just for them.

In a Rockathon held May 26, 1973 in Marion, Ohio 15 yr old John Foreman rocked on uni for 5 hours and 5 minutes. Cathy Fox, age 13 was a close second and rocked 5 hrs, 2 min. Cathy's younger sister Connie took first place in the 11yrs and under group by rocking 35 Min, 45 sec. In a Rideathon (26 mile race course) held in Marion Sept 30, Fred Miller came in first, riding the 26 miles in 3 hrs, 12 min. followed closely by John Foreman 3 hrs, 17 min. The above mentioned Cathy Fox took first place for girls with 3 hrs, 20 Min. Youngest to complete course was Amy Porterfield, 10, who rode the course in 5 hrs, 32 Min.

On Oct. 20, 1973 Long Island's Wantagh Pkwy was closed to autos and cyclists were allowed to ride an approx. 8 mile stretch from Southern State Pkwy to Jones Beach. Some 13,800 cyclists took advantage of good weather and had fun riding the Parkway and the board walk at beach when they arrived. Bill Jenack and son John joined the 13,800 but made it on their unicycles. They did it non stop and the cheers and well wishes of the thousands of bicyclists who passed them on way was very heartwarming.

Tom O. Parish III, age 14, of Neodesha, Kansas rode his uni the complete 20 mile Shiloh Military Trail, Hike #5 from Miss.-Tenn. St. line to park visitors center in Memphis. Only trouble encountered was 3 dogs that insisted on accompanying him. An uncle checking Tom at halfway mark solved problem by giving dogs a lift the rest of way.

Thought the 40" rim used on the Cross-Canada Unicycle of Wally Watts was a giant but just heard via Claude Shannon of Winchester, Mass that a fellow named Goran Lundstrom in Sweden has one with a 56" wheel - you guessed it - Goran is a giant himself, well over 6'

Dr. Ken Veselak, Head of Dept of Health and P.E. at Nassau Community College in Garden City, N.Y. reports the college is now offering an Introductory Circus Arts Course. One of skills being taught is unicycling and already a giraffe uni has been seen circling the parking lot adjoining the Gym.

Dick Haines of the very active Marion Bicycle Club, Marion, Ohio writes that a considerable number of their members are also unicyclists - wonder if this is true of any other bicycle clubs in the country.

Pontiac Unicyclists have been invited to Austria next summer for a series of performances there and they are busy making plans for the overseas trip - what a great Good-will team.

Pete Hangach, Dir. of St. Helen's Unicyclists, Newbury, Ohio reports they've been invited to Dublin, Ireland for St. Pat's Day Parade - Hope they get a sponsor and can make it.

Cindy Williams, member of Jenack Cyclists of Westbury, N.Y. traveled with Circus Kingdom for several weeks this past summer and performed on her unicycle.

13 yr old Richard Joseph Martinez II is back in school again after spending another season riding his Uni and working as a clown in an actual circus. Rick has adopted the name Spangles and is the second youngest known professional clown in America.

Aside from the Honorable Judge Edison Hedges, whose story appears in this newsletter, the year 1972 also claimed the lives of two other great proponents of the sport; Sebastian Merrill Neuhausen of Ramona, California and Rudy Yung of Portland, Oregon. Both Bastian and Rudy were outstanding personalities in the field of unicycling and future issues of the newsletter will carry accounts of their exploits and accomplishments. Bastian, the Dean of American Cyclists, was performing amazing feats on the unicycle before the turn of the century, while Rudy held the distinction of being one of the few talented mechanics who built and successfully rode a motorized monocyte in which he amazed spectators at parades on the west coast for many years. A recent letter from Bob Paddison, an architect student at the Danish Royal Arts Academy in Copenhagen, who now has the monocyte, describes the looks of disbelief on the faces of people as they see Rudy's strange vehicle tooling down the streets of Copenhagen, Denmark under the control of a driver wearing a pilot's helmet of 1917 vintage.

Rudy, Bastian, and Eddie have left us but their colorful lives and accomplishments in the field of unicycling and their work with, and faith in, the youth of our country will live on forever.

EDITORS NOTE:

This brings to a close the first issue of our quarterly newsletter. We hope you are pleased with its format and contents and that it will be a rising curtain which will unveil a whole new world to information-and-news-starved unicyclists everywhere.

New and prospective members may be interested in the aims of the Unicycling Society of America, Inc. which, as stated in our certificate of incorporation as a non-profit organization, are:

To foster social and athletic interest in and promote the healthy, wholesome sport of unicycling among youth and adults of the country by establishing voluntary standards of performance and sponsoring and overseeing local and national meets.

To disseminate knowledge and information on all phases of the sport to all interested parties throughout the country via a newsletter and information service.

We will welcome your suggestions on how to improve the newsletter, what you would like to see included in future issues, and any news of unicycling activity in your area that might be mentioned in the next one.

Best wishes to you all for the New Year 1974 - from the Unicycling Society of America, Inc. officers and staff and from

Your Editor

Bill Jenack

MEMBERSHIP APPLICATION: UNICYCLING SOCIETY OF AMERICA, INC. DATE _____

Check type membership desired, fill in and send with appropriate amount to Secretary - Treasurer Mr. Gordon Kruse, 30246 So. Stockton Drive, Farmington, Michigan 48024. Make checks payable to UNICYCLING SOCIETY OF AMERICA, INC.

_____ Member, \$3.00 annual dues - includes subscription to quarterly newsletter (with quarterly expiration policy) plus membership card, and voting privilege.

_____ Family Member* 50¢ annual dues - for members of immediate family of a member (same benefits as member except the newsletter)

Name of Applicant (please print) _____

Mailing Address _____ City _____ State _____ Zip _____

Age _____ (for statistical purposes) Phone number _____

Field of Interest: Amateur _____ Professional _____

*Please include names of Family Members below

- 1. _____ 4. _____
2. _____ 5. _____
3. _____ 6. _____

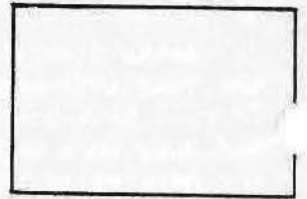

FIRST CLASS

